



ZW 1450 RPM  
ZWD 3400 RPM

# ZW

**Pompe a pistoni ad alta pressione**  
High Pressure piston pump • Bombas de pistones de alta presión

POMPE A PISTONI IN LINEA  
IN-LINE PISTON PUMPS - BOMBAS DE PISTONES EN LINEA



(S Version) ZW

- **ALBERO MASCHIO Ø24 mm** per motore elettrico speciale con albero femmina o per puleggia.
- **SOLID SHAFT 24 mm** for special electric motors with hollow shaft or for pulley drive.
- **ARBOL MACHO Ø24 mm** para motor eléctrico especial con árbol hembra o para polea.

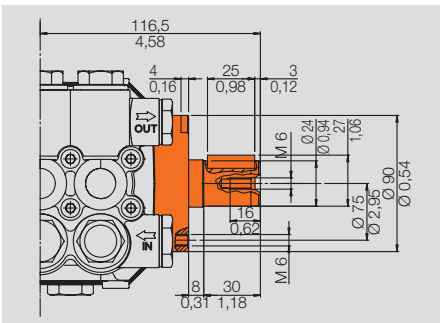

(G Version) ZWD

- **ALBERO FEMMINA Ø1"** per motore a scoppio flangia SAE J 609 A. Flangia inclusa.
- **HOLLOW SHAFT 1"** for petrol engine SAE J 609A. Flange included.
- **ARBOL HEMBRA Ø1"** para motor de explosión con brida SAE J609 A. Brida incluida

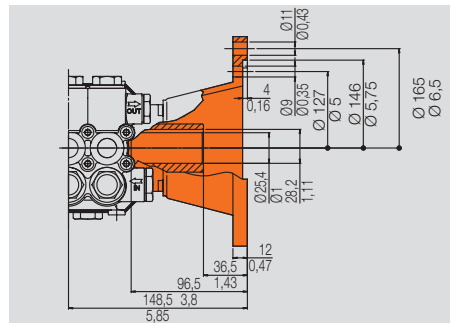

(G Version) ZWD

- **ALBERO FEMMINA Ø3/4"** per motore a scoppio flangia SAE J 609 A. Flangia inclusa.
- **HOLLOW SHAFT 3/4"** for petrol engine SAE J 609A. Flange included.
- **ARBOL HEMBRA Ø3/4"** para motor de explosión con brida SAE J609 A. Brida incluida

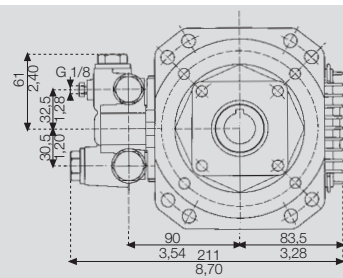
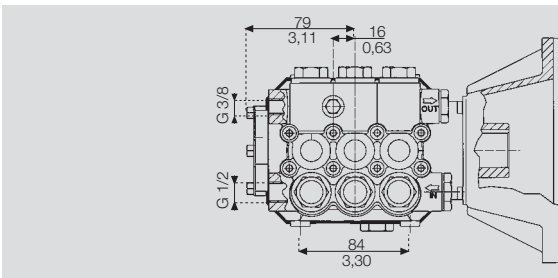
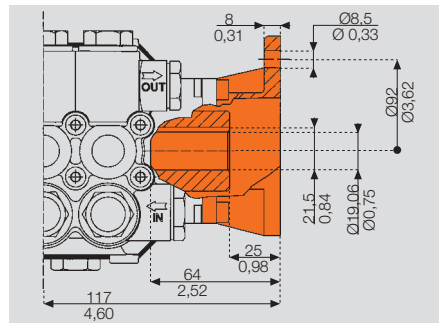

giri/min R.P.M. rev/min	modello model modelo	versione version versione	portata flow rate caudal		pressione pressure presión		potenza assorbita absorbed power potencia absorbida		peso weight peso	
			l/min	US gpm	bar	psi	kW	HP	kg	lb
1450	ZW 4022	S	15,0	4,0	12	2200	4	3,3	7,5	16,5
	ZW 4025	S	15,0	4,0	172	2500	4,2	6,5	7,5	16,5
	ZW 4030	S	15,0	4,0	207	3000	5,5	7,5	7,5	16,5
3400	ZWD 2530	G	9,4	2,5	207	3000	3,7	5,0	7,5	16,5
	ZWD 2535	G	9,4	2,5	240	3500	4,5	5,8	7,9	17,4
	ZWD 3030	G	11,0	3,0	207	3000	4,4	6,0	7,9	17,4
	ZWD 3035	G	11,0	3,0	240	3500	5,1	7,0	7,9	17,4
	ZWD 3040	G	11,0	3,0	276	4000	5,8	7,9	7,9	17,4
	ZWD 3035	G	11,0	3,0	240	3500	5,1	7,0	7,9	17,4
	ZWD 3530	G	13,0	3,4	207	3000	4,8	6,5	7,9	17,4
	ZWD 3535	G	13,0	3,4	240	3500	5,6	7,6	7,9	17,4
	ZWD 3540	G	13,0	3,4	276	4000	7,0	9,5	7,9	17,4
	ZWD 4030	G	15,0	4,0	207	3000	5,5	7,5	7,9	17,4
	ZWD 4035	G	15,0	4,0	240	3500	6,4	8,7	7,9	17,4
ZWD 4040	G	15,0	4,0	276	4000	8,2	11,0	7,9	17,4	

- Tutti i modelli sono forniti con testata in ottone e in versione standard con presa di moto lato destro; a richiesta con presa di moto lato sinistro. I modelli a 1450 R.P.M. sono forniti con il dispositivo **EASY-START** che garantisce la partenza del motore in ogni condizione.
- All models supplied with brass head. Standard versions with p.t.o on right hand side, left hand side p.t.o. supplied on request. Models a 1450 R.P.M. are equipped with **EASY-START** device, assuring electric motor start in all electrical difficult conditions.
- Todos los modelos están disponibles con cabeza de latón y en las versiones estándar con toma de movimiento sobre el lado derecho. Sobre demanda con toma de movimiento en el lado izquierdo. Los modelos a 1450 R.P.M. son equipados del sistema **EASY-START** que garantiza un arranque del motor electric en cualquiera condiccion.